

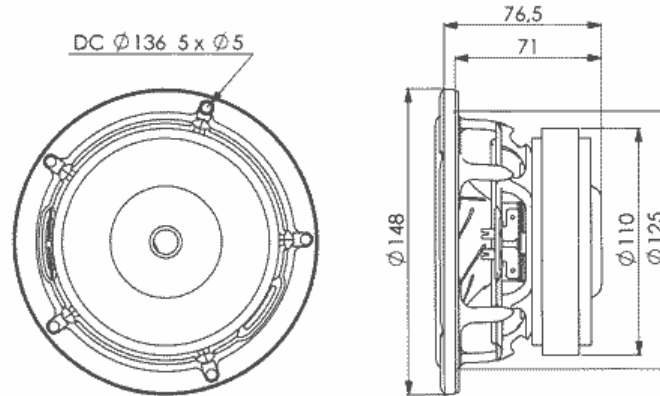

# 15W/4531G00

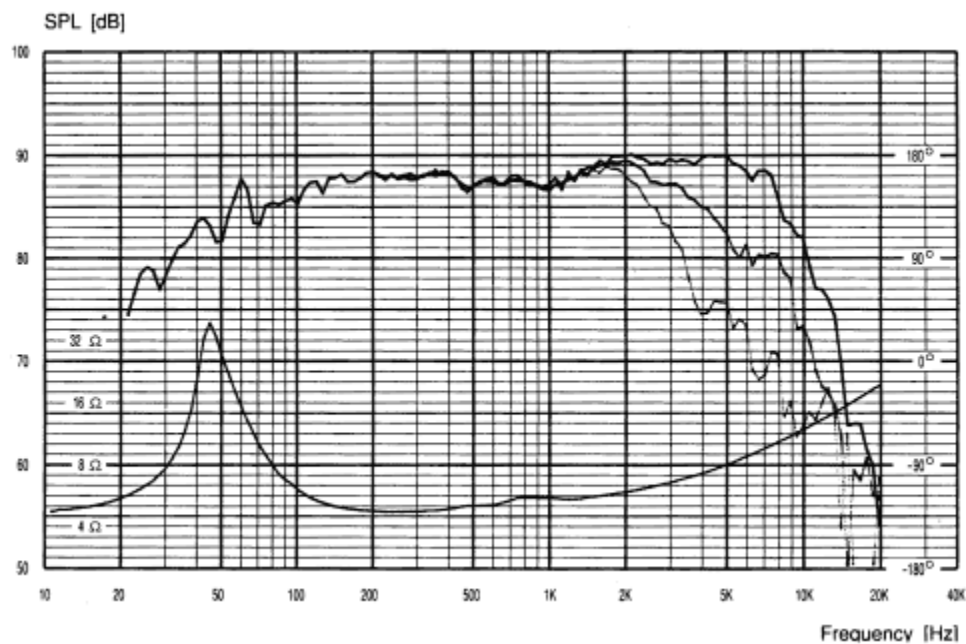

Characteristic sensitivity (2.83V / 1m)	: 87 dB
Recommended frequency range	: 30 - 6000 Hz
Free air resonance frequency, $f_s$	: 39.5 Hz
DC resistance, $R_e$	: 3.4 ohm
Voice coil inductance, $L_e$	: 0.25 mH
Effective piston area, $S_d$	: 95 cm <sup>2</sup>
Moving mass incl. air, $m_d$	: 13 g
Mechanical loss, $R_m$	: 0.7 Ns/m
Force factor, $BL$	: 5.7 Tm
Equivalent volume, $V_{as}$	: 16 ltr.
Mechanical Q-factor, $Q_{ms}$	: 4.6
Electrical Q-factor, $Q_{es}$	: 0.34
Total Q-factor, $Q_{ts}$	: 0.32
Excursion, lin./max.	: $\pm 6.5 / \pm 9$ mm
Voice coil diameter	: 38 mm
Rated power handling	: 60 W
Net weight	: 1.6 kg



**Frequency response: 2.83V / 1m**